



Maimin Technology Group, Inc.

70 King Street, Elk Grove Village, Illinois 60007 USA

☎ 847-709-2500 • FAX 847-709-2599 • 🌐 www.maimin.com • email: sales@maimin.com

MODEL K-205

SEMI-AUTOMATIC END CUTTING SYSTEM

MODEL K-405

FULLY-AUTOMATIC END CUTTING SYSTEM

PARTS AND INSTRUCTIONS BOOK

SERIAL NUMBER STARTING WITH SAEC15-/FAEC15- OR SAEC25-/FAEC25-

From the library of: Superior Sewing Machine & Supply LLC

EFFECTIVE 12/02

SAFETY PRECAUTIONS

This instruction manual describes the operation and function of a Maimin End Cutting System. Read this manual carefully to ensure safe use and maximum performance from your machine.

Failure to follow instructions may lead to injury (cuts, electric shock, burns, fire, or injury to persons). This machine is for commercial use only. Read all instructions before using.

The purchaser must instruct all operators on the proper use of this equipment. All standard industrial safety measures and equipment should be provided to protect the operator. Operators must be cautioned that improper or careless use of this equipment may cause personal injury. If you do not have qualified operators to instruct new persons, contact MAIMIN directly, or an authorized distributor or representative.

WARNINGS

Danger!

Sharp Blade!

Moving Parts!

Electric Connections!

Keep hands, fingers, all other bodily parts, clothing and jewelry away from blade and moving parts.

To reduce the risk of electric shock, do not install or store this machine in a wet location.

To reduce the risk of cuts, electric shock, burns, fire, or injury to persons:

1. Use machine only for its intended use
2. Turn machine to "OFF" (O) before connecting or disconnecting power cord
3. Connect this machine to a properly grounded outlet only. See Grounding Instructions.
4. Always disconnect electrical connection when not using, servicing, or maintaining machine.
5. Do not leave machine unattended while it is connected to a power outlet.
6. Do not operate machine with a damaged cord or if machine has sustained damage. Do not disassemble; use a qualified serviceman for repairs. Incorrect assembly can cause electric shock when the machine is used.
7. Keep hands, fingers, all other bodily parts, clothing and jewelry away from blade and moving parts.
8. Keep guards in place and in working order.
9. The knife key and other wrenches must be removed from the cutting machine before starting motor.
10. Keep ventilation openings free from dust and lint.
11. Keep machine clean and blade sharp for best and safest performance.

**THESE WARNINGS SHOULD BE POSTED IN A VERY CONSPICUOUS LOCATION IN
CLOSE PROXIMITY TO THE MACHINE.**

From the library of: Superior Sewing Machine & Supply LLC

Grounding Instructions

This machine must be grounded. In the event of malfunction or breakdown, grounding provides a path of least resistance for electric current to reduce the risk of electric shock.

Danger! Improper connection to electric source can result in a risk of electric shock. Check with a qualified electrician or serviceman who is familiar with applicable codes and regulations if the grounding instructions are not completely understood or if in doubt as to whether this machine is properly grounded. Disconnect this equipment from electrical power source before proceeding with any disassembly for adjustment or repair.

Use correct wire sizes with this machine.

USA ONLY: 1 phase: Use AWG16/3 SJ, SJT or SJE

3 phase: Use AWG 16/4 SJ, SJT or SJE

INTERNATIONAL: 1P+N+: Use 3 x 1,0 mm CEE (2) 61

3P+: Use 4 x 1,0 mm CEE (2) 61

General Precautions

- This machine is equipped with a very sharp blade and other moving parts. Leave all guards in their proper position.
- Always wear safety glasses when operating or servicing this equipment.
- Do not operate until all instructions for this machine have been read.
- This equipment includes a cutting machine that is designed to run at high speed across the track. Equipment should be set up with a minimum of 3 feet (1 meter) clear path at front and rear.
- All personnel should be instructed to stand well clear of this equipment when in operation.
- At startup and during operation, be sure to monitor the functions and performance of the machine and all components.
- We recommend that you take substantial safety measures to avoid any damage in the event a problem occurs.
- Do not open or modify the machine or any of its components or use these in any way other than described in the specifications.
- Do not use the machine or any of its components for the purpose of protecting the human body.

Installation Instructions

1. Following the diagram, affix lift motor set clamp (A) to the right side of the cutting table.
2. Affix other set clamp (B) to the left side of the cutting table, opposite the lift motor set clamp (A).
3. Fasten one end of the Lift Belt into the Belt Press Piece of the Clamp Assembly, and then pass the other end through the Roller of the Bar Lifter, crossing under the Rail Thread through the Roller of the Bar Lifter, then through the Down Roller on the Bar Lifter. Tighten the Belt Press Piece.
4. Place Rail (C) onto Lift Rod. Note: The end with power line out should be placed at the Lift Motor Set Clamp side.
5. Fasten both ends of the Rail (C) onto the Lift Rod with Set Screws (E).
6. Hook the Gear Belt Hook (F) from bottom upward onto the rear side. Put Cutter (G) inside Rail (C).
7. Affix Transmission Motor Assembly (H) at the power line out end, with Rail Fixing Screw (E), and connect the two plugs.
8. Affix Belt Pulley (I) at the other end of the Rail with Rail Fixing Screw (E).
9. Wind the other end of the belt across Transmission Gear (H), through bottom of the Rail ©, up to the opposite side Belt Pulley, back to inside of Rail (C), and then hook on to the front of the Cutter. (Note: inspect the Belt to make sure it is not twisted).
10. Adjust Gear Belt by using Belt Adjusting Screw (J) to a suitable tension (about ¼ inch).
11. Install Control Box Frame (K), and place Control Box (L) onto it.
12. Installation of wiring bracket:
 - a. Affix Set Clamp (M) to Cutting Table.
 - b. Install Wiring Pipe (N) and Supporting Bracket (O).
 - c. Lead twin hole electric wire (Q) through Wiring Pipe (R) downward from the top.
 - d. Install receptacle with suitable reserve length, and affix it with the Binding Belt.
13. Insert cables into appropriate two-hole, five-hole and seven-hole receptacles on the underside of the Control Box (L).

For proper operation, LED lights should be as follows (open Control Box Cover and press Start Button to view):

LED 5 lights up:	Cutter is rotating.
LED 5 goes out:	Cutter stops rotating.
LED 6 and LED 8 light up:	Cutter reversing and track lifts up (LED 2 goes out)
LED 6 goes out:	Track Lift stops.
LED 8 goes out:	Cutter stops reversing.
LED 7 lights up:	Track is going down.
LED 2 lights up:	Track has reached the bottom.
LED 7 goes out:	Track stops going down.

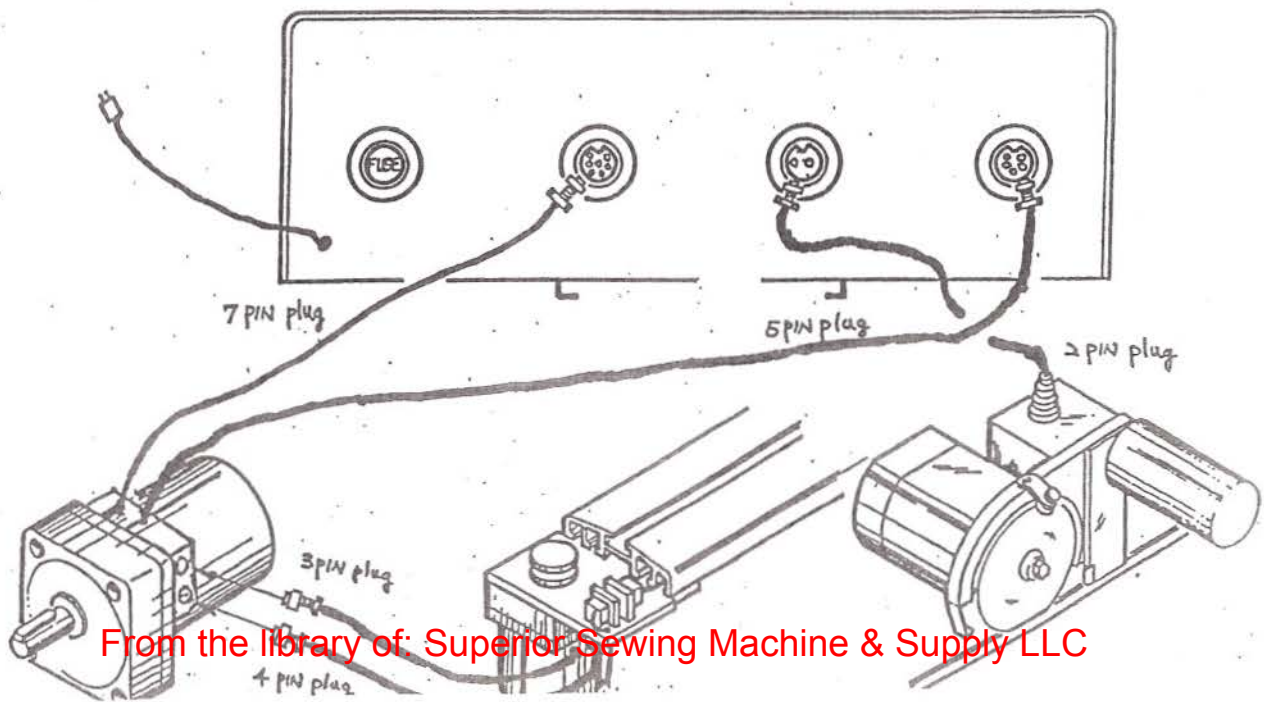
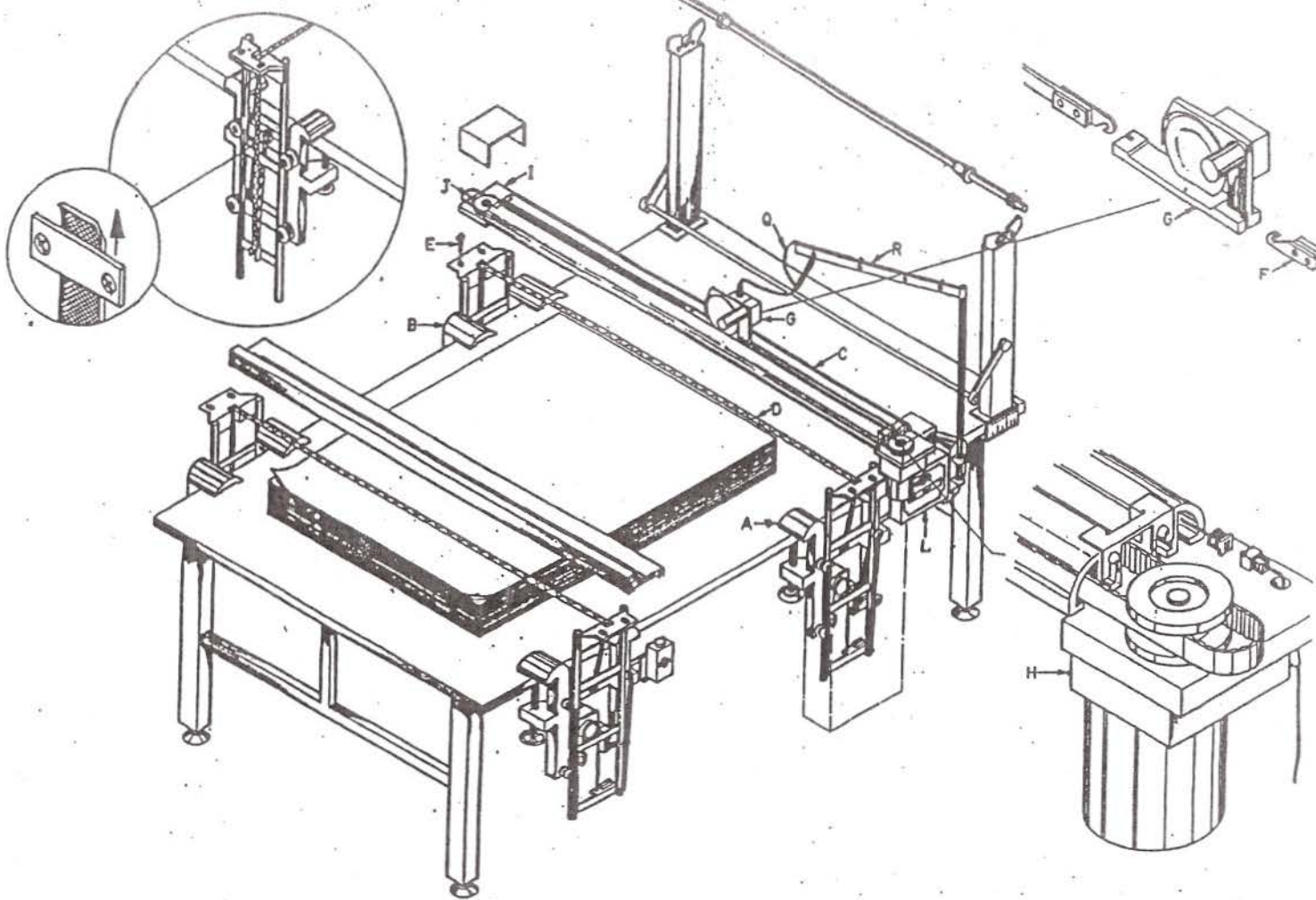

From the library of: Superior Sewing Machine & Supply LLC

OPERATING INSTRUCTIONS

1. Before operating the machine, make sure the track surface is clean and clear of debris.
2. Turn the power switch to On (1) (Switch lights up)
3. Push the START button, then **ALLOW AT LEAST 5 SECONDS** for the Control Box to reset.
4. Push the SHARPENING (WHETTING) button (Switch lights up), and sharpen the Blade by pushing the Grinding Wheel (part no.2623) into the Blade several times. Then, push the SHARPENING button again to stop the sharpener function.
5. To use the Counter, switch off the STOP COUNTER switch and push the COUNTER reset button to 0000.
6. A) Pull cloth across the track and to desired length.

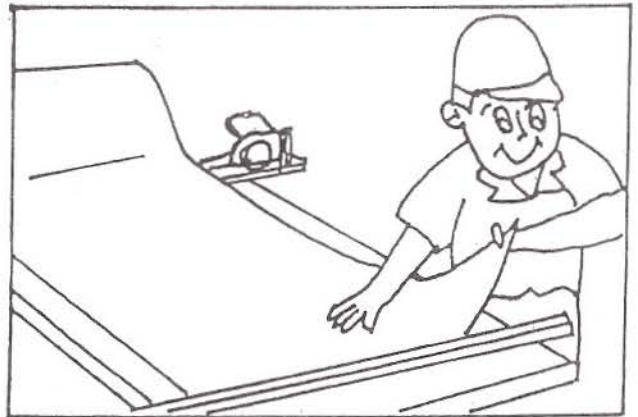

B) Secure with END RAIL if included.

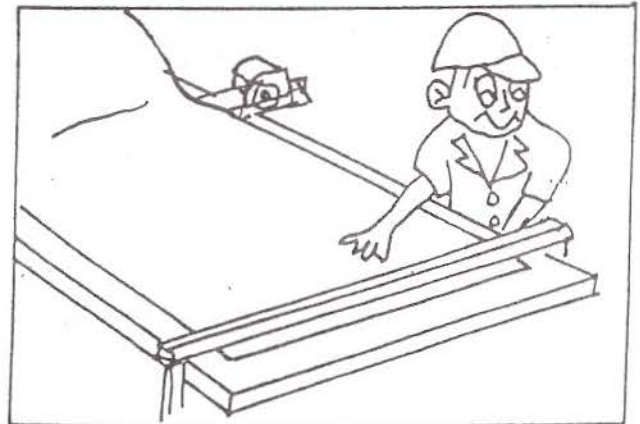

C) Push START button and the cutter will automatically cut the cloth that was laid across the track. If automatic lifters are included, the track will move up and down. If not, manually lift the track and allow the cloth to fall underneath before lowering track back to table.

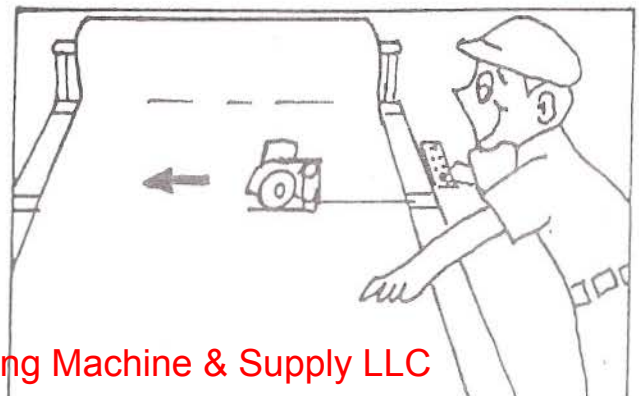

FUNCTION OF CONTROL BOX KEYS

<u>Key Name</u>	<u>Function</u>
Power:	To turn Power on or off. Off is indicated as 'O', On is indicated as '1'. Lights up to show power is on.
Length Setting (Dial):	Sets distance Cutter will move on track. Turn to the right for a longer distance, turn to the left for a shorter distance.
Counter:	To count number of plies that have been cut.
Stop Counting:	To deactivate counter.
Emergency Stop:	Stop all operation of the machine.
Up:	To manually lift the track (automatic lift version only).
Down:	To manually lower the track (automatic lift version only).
Sharpening: (or "Whetting")	To turn on Cutter for sharpening. Cutter Blade will rotate when pushed. While blade is rotating, push Grinding Wheel into Blade for Sharpening. Cutter will not move along track. Switch lights up to indicate operation.
Start:	Activates Cutter to move automatically across track, and activates Lifters (automatic lift version only).

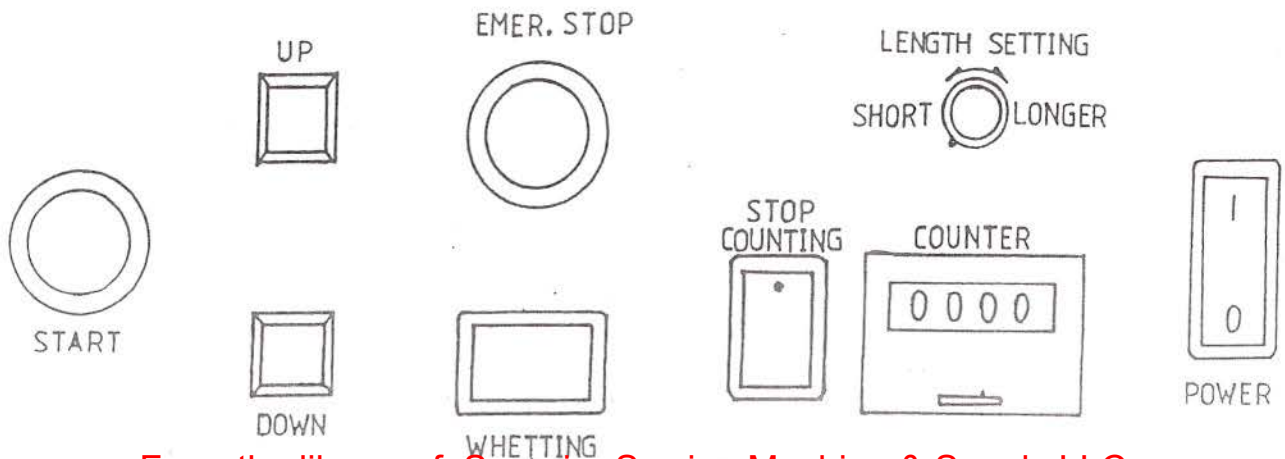

SIMPLE TROUBLESHOOTING

Open the Control Box Cover:

LED 5 lights up:	Cutter is rotating and goes
LED 5 goes out:	Cutter rotating and stops
LED 8 and LED 6 light up:	Cutter reversing and track lift (LED 2 goes out)
LED 8 goes out:	Cutter reversing stop
LED 6 goes out :	Track lift stop
LED 7 light up :	Track moving down
LED 2 light up :	Track has reached the bottom
LED 7 goes out :	Track moving down stop

SIMPLE TROUBLE SHOOTING

1. When the track only goes up and will not go down, it is probably caused by:
 - a) The wire to the motor controlling up-and-down movement is broken.
 - b) Microswitch malfunction.
Check wire first. If not broken, check the LED 2 Light. If the light doesn't light up, this may indicate that it switch is stuck. Adjust or replace the Microswitch under the track if necessary.
2. When the track does not stop when moving down, or its chain easily drops off, it is probably caused by:
 - a) Microswitch malfunction.
Check if the LED 2 Light stays lit. If the light doesn't light up, this may indicate that no signal for stopping the track's descent is not being read. Straighten the Microswitch and check the circuit. Adjust or replace the Microswitch under the track if necessary.
3. When the cutter blade doesn't rotate, it is probably caused by:
 - a) A broken wire between the control box and the cutter.
If the cutter advances part way, there is an output of power; in this case, check the outer circuit and the control box.
3. When a the cutter does not slow down and hits the far end of the track, it is probably caused by:
 - a) The signal to reverse is not being read.
Open the control box and check the LED 4 Light; if the lights don't light up, this indicates that no signal for reversing is being read. In this case, inspect the outer circuit with an electric meter to see if circuits and/or Sensor Switch are broken.
6. When a slight bump occurs every time the cutter advances and reverses, and it does not return to the base, it is probably caused by

- a) Improper position of the “Sensor Magnetic Spring Switch” which controls advancing, reversing and stopping,
Move the “Sensor Switch” to the proper position.
 - b) The TIMING belt is not properly set;
Adjust the tension of the TIMING belt until there is 5mm elasticity.
7. When the cutter doesn't run smoothly, it is probably caused by:
- a) The TIMING belt is not properly set;
Adjust the tension of the TIMING belt until there is 5mm elasticity.
 - b) The inner part of the track is clogged with residue;
Clean the inner part of the track, or draw out the copper plate inside the track and clean the bottom part. After resetting the copper plate, drop some sewing machine oil on before placing the cutter back in the track.
 - c) The track surface is dented or damaged.
Replace the track.
8. When the START switch is pressed, and the cutter blade rotates but the machine does not advance, this is probably caused by:
- a) Poor contact of the connected wire
Check the black and yellow wire, adjust or replace as necessary.
 - (b) Motor problem.
Check the motor, repair or replace as necessary.
9. When the START switch is pressed, and the machine advances and returns but the cutter blade does not rotate or the track does not ascend or descend, this is probably caused by:
- (a) Loose connection of the 5-pin plug
Check connection.
 - (b) Loose wiring of the motor controlling ascent and descent of track
Check wiring.
 - (c) Motor problem.
Check the motor, repair or replace as necessary.

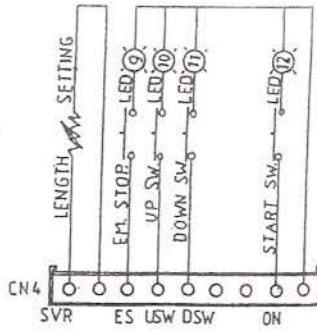
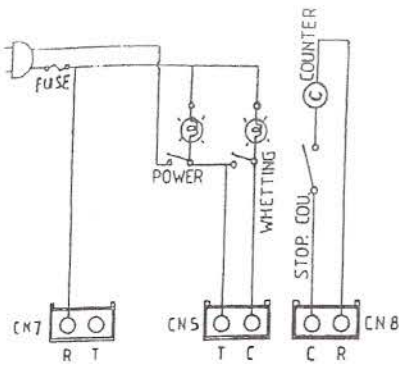

SIGNAL INPUT LIGHT: GREEN

LED 1 : S1-BACK STOP SENSOR

LED 2 : S6-DOWN STOP SWITCH

LED 3 : S7-UP TOP SENSOR

LED 4 : S2-RETURN SENSOR

LED 9 : EMER. STOP SWITCH

LED10 : UP SWITCH

LED11 : DOWN SWITCH

LED12 : START SWITCH

POWER OUTPUT LIGHT: RED

LED 5 : CUTTER MOTOR TURN. AND GC

LED 6 : TRACK LIFT

LED 7 : TRACK DOWN

LED 8 : CUTTER RETURN

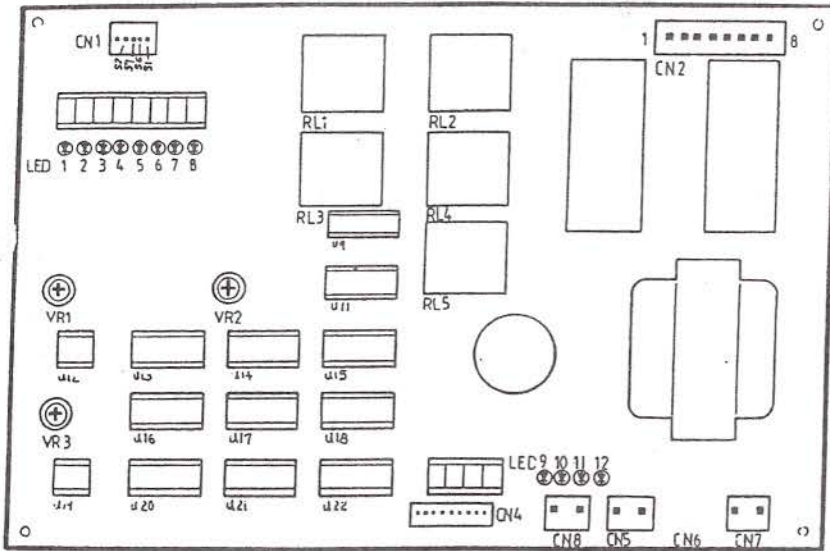

AC OUT PUT

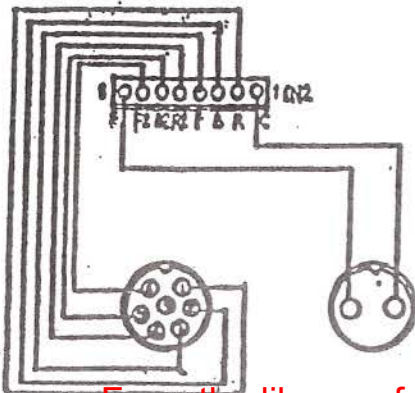

DC IN PUT

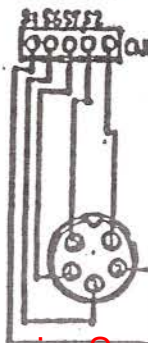

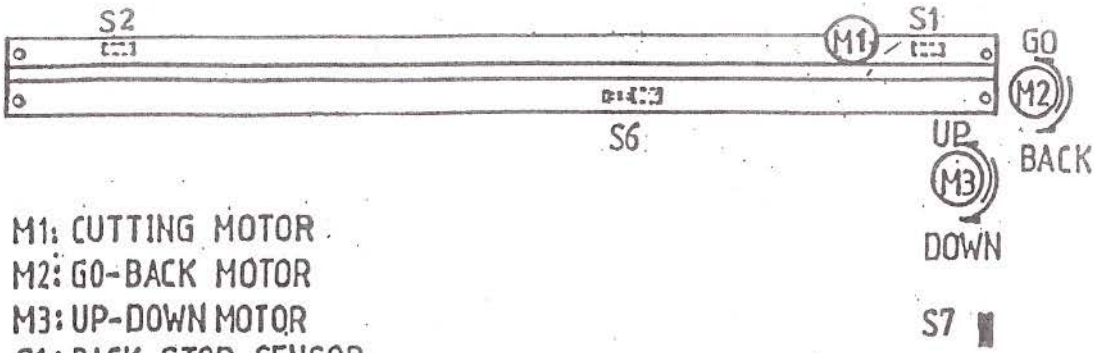

- M1: CUTTING MOTOR
- M2: GO-BACK MOTOR
- M3: UP-DOWN MOTOR
- S1: BACK STOP SENSOR
- S2: RETURN SENSOR
- S6: DOWN STOP MICRO SWITCH
- S7: UP TOP SENSOR

AC OUTPUT

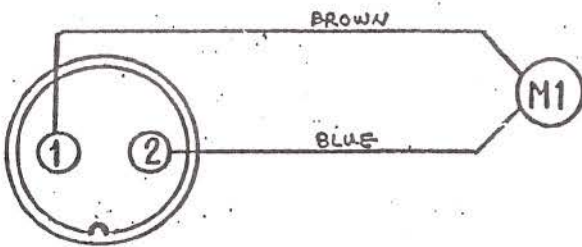

AC OUTPUT

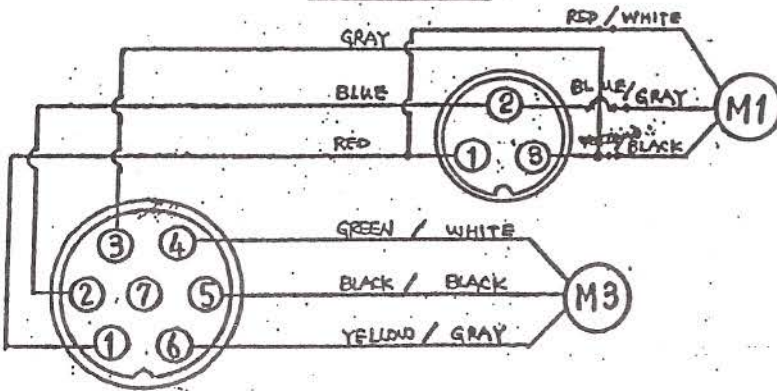

DC INPUT

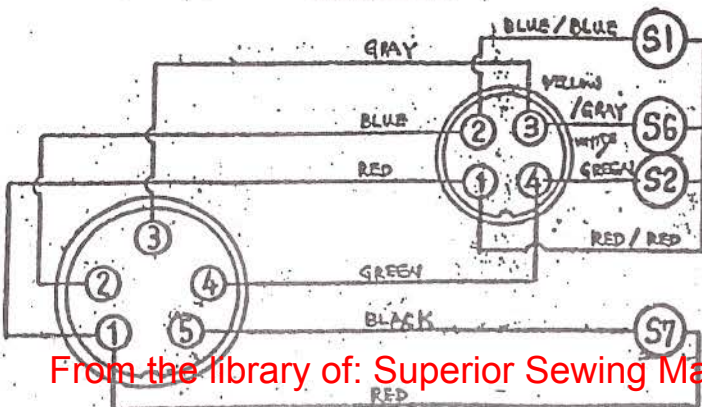

ROUTINE MAINTENANCE INSTRUCTIONS

ADJUSTING THE GRINDER SHARPENER:

When the blade is worn, adjust the grinder position by unscrewing the Screw for the Grinder Arm so as to ensure a correct distance between the Grinder and the edge of the Blade. After finishing adjustment, re-tighten the screw.

REPLACING THE GRINDING WHEEL:

1. Remove the Grinding Wheel (2626) by unscrewing it.
2. Mount the new Grinding Wheel and re-tighten the screw.

REPLACING THE BLADE:

1. Remove Grinding Wheel Unit (F).
2. Remove Guard.
3. Unscrew the Lock Nut (G) for the Blade.
4. Take off the Blade.
5. When mounting the new Blade, make sure that the side with printing is facing the operator.
6. After the Blade is replaced, adjust the position of the Grinder (B) as described above.

REPLACING THE LOWER BLADE:

1. Remove the Screw For Lower Blade Arm (H).
2. Remove the Lower Blade Arm.
3. Replace the Lower Blade, ensuring the flat surface of the Lower Blade is adjacent to the Blade edge.

REPLACING THE CARBON BRUSH:

Carbon Brush must be replaced when it wears to 5-6 mm long. Too much wear will cause motor problems. To replace the Carbon Brush:

1. Remove Carbon Brush Cap (I) by turning it counter-clockwise.
2. Always replace both Right and Left Carbon Brushes at the same time.

MAINTAINING A CLEAN TRACK AND MACHINE:

1. Clean all residues in the track thoroughly every 10 to 20 hours of running time.
2. Remove the cutting machine from the track and thoroughly clean it every 30 days of running time.

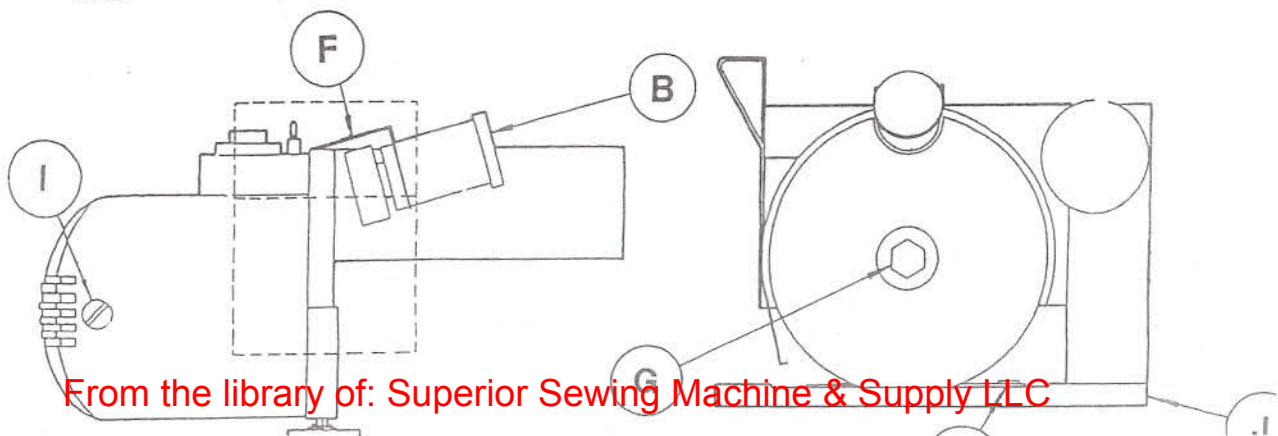

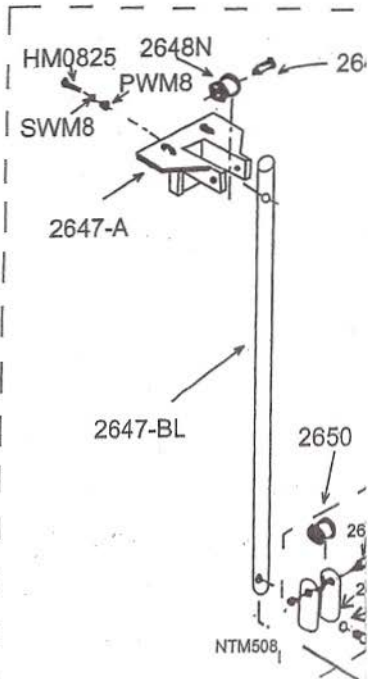
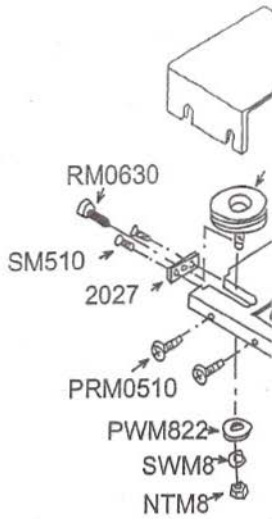

PART NO.

DESCRIPTION

EC 260110-110	110V MOTOR ASSEMBLY
EC 260110-220	220V MOTOR ASSEMBLY
EC 2601-110	110V STATOR
EC 2601-220	220V STATOR
EC 2602-110	110V ARMATURE
EC 2602-220	220V ARMATURE
EC 2603	WASHER FOR ARMATURE
EC 2606	O RING
EC 2607	MOTOR COVER
EC 2608	SCREW FOR STATOR
EC 2609	MOTOR PLATE
EC 2610	RUBBER FOR BEARING
EC 2613	SCREW FOR PRESSURE SPRING
EC 261416	LOWER BLADE SET
EC 2614	LOWER BLADE ARM
EC 2614-3	LOWER BLADE #3
EC 2615	LOWER BLADE
EC 2616	SCREW FOR LOWER BLADE
EC 2617	SCREW FOR LOWER BLADE ARM
EC 2617-3	SCREW FOR LOWER BLADE #3
EC 2618	BALANCE IRON
EC 262327	SHARPENER ASSEMBLY
EC 2623	SHARPENER COLLAR
EC 2624	SPRING FOR SHARPENER COLLAR
EC 2625	STONE ARM (TOP)
EC 2626	STONE COMPLETE
EC 2630N	LOCK NUT FOR KNIFE
EC 2631	BLADE 30331 ENDCUTTER EA
EC 2633	KNIFE GUARD
EC 2633C	KNIFE COVER
EC 2634	TERMINAL BOX
EC 2638	COVER FOR TERMINAL BOX
EC 2001	STANDARD FOR K-405
EC 2001-A	LINK FOR TIMING BELT
EC 2002	MAGNET FOR SENSOR
EC S104	CARBON BRUSH
EC S105	CAP FOR CARBON BRUSH
EC S178	PRESSURE SPRING FOR LOWER BLADE
458B	CONNECTOR 1PH
405NX	TERMINAL BLOCK ASSEMBLY

PART NO.	DESCRIPTION
EC 263946N-L	LEFT CLAMP SET
EC 2639N	A CLAMP
EC 2640	LIFT BELT CATCH
EC 2645	SCREW
EC 2646	WASHER FOR SCREW
EC 264750N	LEFT BAR LIFTER
EC 2647-A	BAR LIFTER PLATE
EC 2647-BL	LEFT BAR LIFTER
EC 2648N	ROLLER FOR LIFT BELT
EC 2649	ROLLER SHAPE
EC 2650	ROLLER SET
EC 2653	RAIL
EC 2654	SQUARE NUT
EC 2655	RAIL GUARD
EC 2656	IMPACT-RESISTANT RUBBER
EC 2657	STEEL PIECE
EC 2658	RAIL RUBBER
EC 2660	SCREW FOR RAIL
EC 2662	LIFT BELT
EC 200725-110	TRANSMISSION MOTOR 110V
EC 200725-220	TRANSMISSION MOTOR 220V
EC 2007	GEAR LATCH
EC 2011N-110	F.R. MOTOR 110V
EC 2011N-220	F.R. MOTOR 220V
EC 2013	SENSOR SWITCH
EC 2018	TRANSMISSION BASE COVER
EC 2019	SPRING FOR EC2656
EC 2020	RAIL PLUG SOCKET
EC 2021	TRANSMISSION GEAR
EC 2021-A	SCREW FOR TRANSMISSION GEAR
EC 2022	F.R. MOTOR BASE
EC 2022A	F.R. MOTOR TERMINAL BOX
EC 2023N	REDUCTION GEAR
EC 202427	TRANSMISSION PULLEY SET
EC 2024	TRANSMISSION PULLEY BASE
EC 2025-3	3-HOLE CABLE
EC 2025-4	4-HOLE CABLE
EC 2026	TRANSMISSION PULLEY
EC 202641	GUIDE ROLLER
EC 2027	PULLEY FIXED BLADE
EC 202830	K205 RAIL ASSEMBLY
EC 2028	RAIL
EC 2029	MICRO SWITCH
EC 2030	RAIL PLUG SOCKET
EC 2042	TIMING BELT

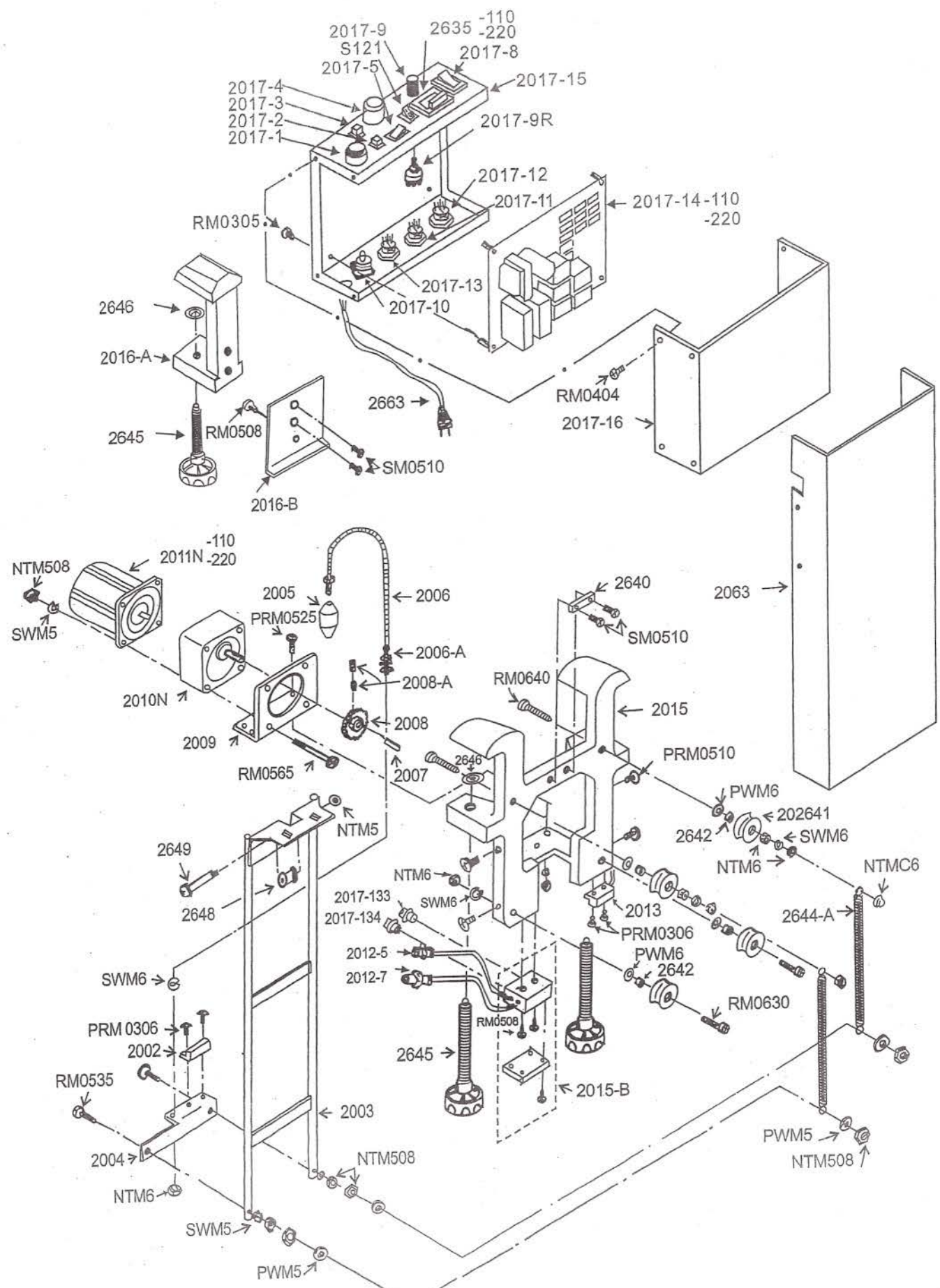

PART NO.	DESCRIPTION
EC 2002	MAGNET FOR SENSOR
EC 2003	LIFTER
EC 2004	MAGNET BASE
EC 2005	CHAIN PENDANT
EC 2006	CHAIN
EC 2006-A	CHAIN SCREW
EC 2007	GEAR LATCH
EC 2008	CHAIN GEAR
EC 2009	F.R. MOTOR PLATE
EC 2010N	REDUCTION GEAR FOR LIFTING
EC 2011N-110	110V F.R. MOTOR
EC 2011N-220	220V F.R. MOTOR
EC 2012-5	CABLE 5-HOLE
EC 2012-7	CABLE 7-HOLE
EC 2013	SENSOR SWITCH
EC 2015	LIFTING FIXED CLAMP
EC 2015-B	LIFTING MOTOR TERMINAL BLOCK
EC 2016	CONTROL BOX STANDARD
EC 2017-110	CONTROL BOX ASSEMBLY 110V
EC 2017-220	CONTROL BOX ASSEMBLY 220V
EC 2017-1	START SWITCH
EC 2017-2	DOWN SWITCH
EC 2017-3	UP SWITCH
EC 2017-4	EMERGENCY STOP SWITCH
EC 2017-5	SHARPEN SWITCH
EC 2017-8	POWER SWITCH
EC 2017-9	LENGTH SETTING TUNER CAP
EC 2017-9R	LENGTH SETTING TUNER
EC 2017-10	FUSE BASE
EC 2017-11	PLUG 2-HOLES
EC 2017-12	PLUG 5-HOLES
EC 2017-13	PLUG 7-HOLES
EC 2017-14-110	PC BOARD 110V
EC 2017-14-220	PC BOARD 220V
EC 2017-133	PLUG 3-HOLES
EC 2017-134	PLUG 4-HOLES
EC 2017-15	CONTROL BOX CASE
EC 2017-16	CONTROL BOX COVER
EC 2063	LIFT SET COVER
EC 2635-110	COUNTER 110V
EC 2635-220	COUNTER 220V
EC 2640	LIFT BELT CATCH
EC 2642	WHEEL RING
EC 2644-A	SPRING FOR LIFT
EC 2645	SCREW
EC 2646	WASHER FOR SCREW
EC 2648	ROLLER
EC 2649	ROLLER SWITCH
EC S121	SWITCH



PART NO.	DESCRIPTION
EC 2003	LIFTER
EC 2004	MAGNET BASE
EC 2005	CHAIN PENDANT
EC 2006	CHAIN
EC 2007	GEAR LATCH
EC 2008	CHAIN GEAR
EC 2009	F.R. MOTOR PLATE
EC 2010	REDUCTION GEAR
EC 2011	F.R. MOTOR
EC 2012	MOTOR PLUG
EC 2015	LIFTING FIXED CLAMP
EC 2029	MICRO SWITCH
EC 2043	2 PIN PLUG
EC 2044	ELECTRIC BOX
EC 2044-1	UP SWITCH
EC 2017-8	POWER SWITCH
EC 2061	CLOTH PRESS TRACK SET